



# Building optical networks in Brazil

## Panel “Interconnecting RONS and NRENS and national infrastructure”

Internet2 Fall Members’ Meeting  
Philadelphia, September 2005

Michael Stanton  
Director of Innovation  
Rede Nacional de Ensino e Pesquisa - RNP  
*michael@rnp.br*

# Summary



- New optical transmission and switching technologies allow significant reduction in the costs of setting up and operating research and education networks.
- By means of examples we show how these opportunities are being exploited in Brazil.
- Our agenda:
  - A brief look at RNP
  - Project GIGA – an optical networking testbed
  - IPÊ – the next-generation national network
  - Redecomep – Community-based Optical Metropolitan Networks
  - Project ION-NE: synergy between testbed and service networking

# Introduction to Brazil

Tordesillas Line



- Origins: The territories that became Brazil were explored and occupied by the Portuguese from 1500. Before that, in 1494 Spain and Portugal had divided between themselves undiscovered lands by the Treaty of Tordesillas
  - Tordesillas Line was to be the frontier between the dominions of Spain (W) and Portugal (E)
- Brazil is the successor country to the Portuguese dominions in South America
  - Rather over one half of present Brazil lies to the WEST of the Tordesillas Line
- Brazil is a **BIG** place!
  - diameter of about **5,000 km**
- Current population of about **170 millions**, unevenly distributed
  - most of the population and communications infrastructure concentrated to the EAST of the Tordesillas Line

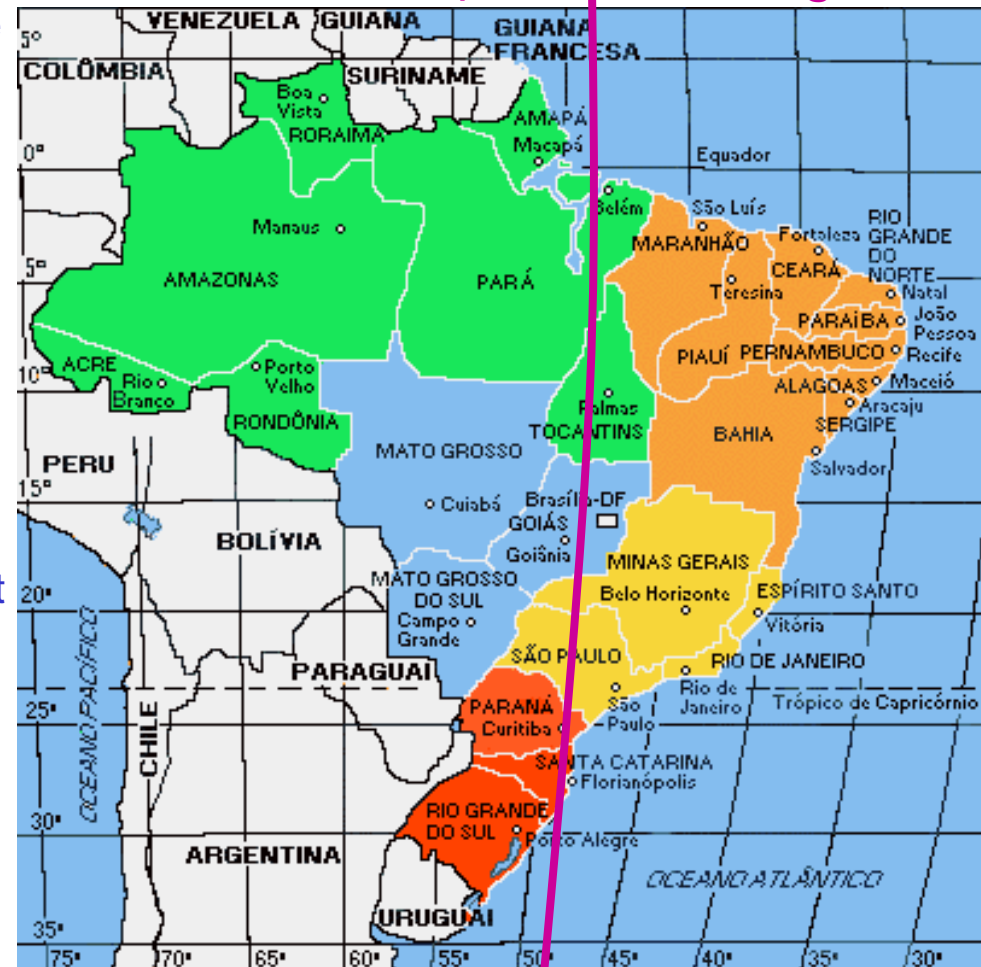

# RNP – Rede Nacional de Ensino e Pesquisa



- RNP is the Brazilian national research and education network
  - maintained by the Brazilian government (since 1989)
  - provides national (inter-state) and international connectivity for more than 400 universities and research centers through the provision of advanced networking infrastructure
    - collaboration – links to other similar networks internationally (Internet2, GÉANT, APAN, RedCLARA)
    - commodity – links to the commercial Internet
  - supports the development of advanced networking and applications
- RNP is managed for the federal government by a non-profit private company, RNP-OS

# Evolution of academic networks in Brazil



Year	Technology	Link capacities	Comment
1988	BITNET	up to 9.6 kbps	first national network
1992	Internet	9.6 and 64 kbps	first national IP network (RNP)
1995		up to 2 Mbps	<i>a/so:</i> commercial IP deployed
1999	IP/ATM, IP/FR	VC up to 45 Mbps, access up to 155 Mbps	RNP2 national backbone; testbed metro networks in 14 cities (using ATM/dark fiber)
2003	IP/SDH	34, 155, 622 Mbps	<i>a/so:</i> IP/WDM interstate testbed network (Project GIGA)
2005	IP/WDM	2.5 and 10 Gbps	IPÊ national backbone; metro networks in 27 capitals

# Current RNP2 backbone network



- Introduced in 2004/5
- IP/SDH (replacing IP/ATM)
- first multi-provider network
  - until late 1990s telcos were state monopolies
- 6x the aggregate capacity of the previous (ATM) network at 2/3 cost

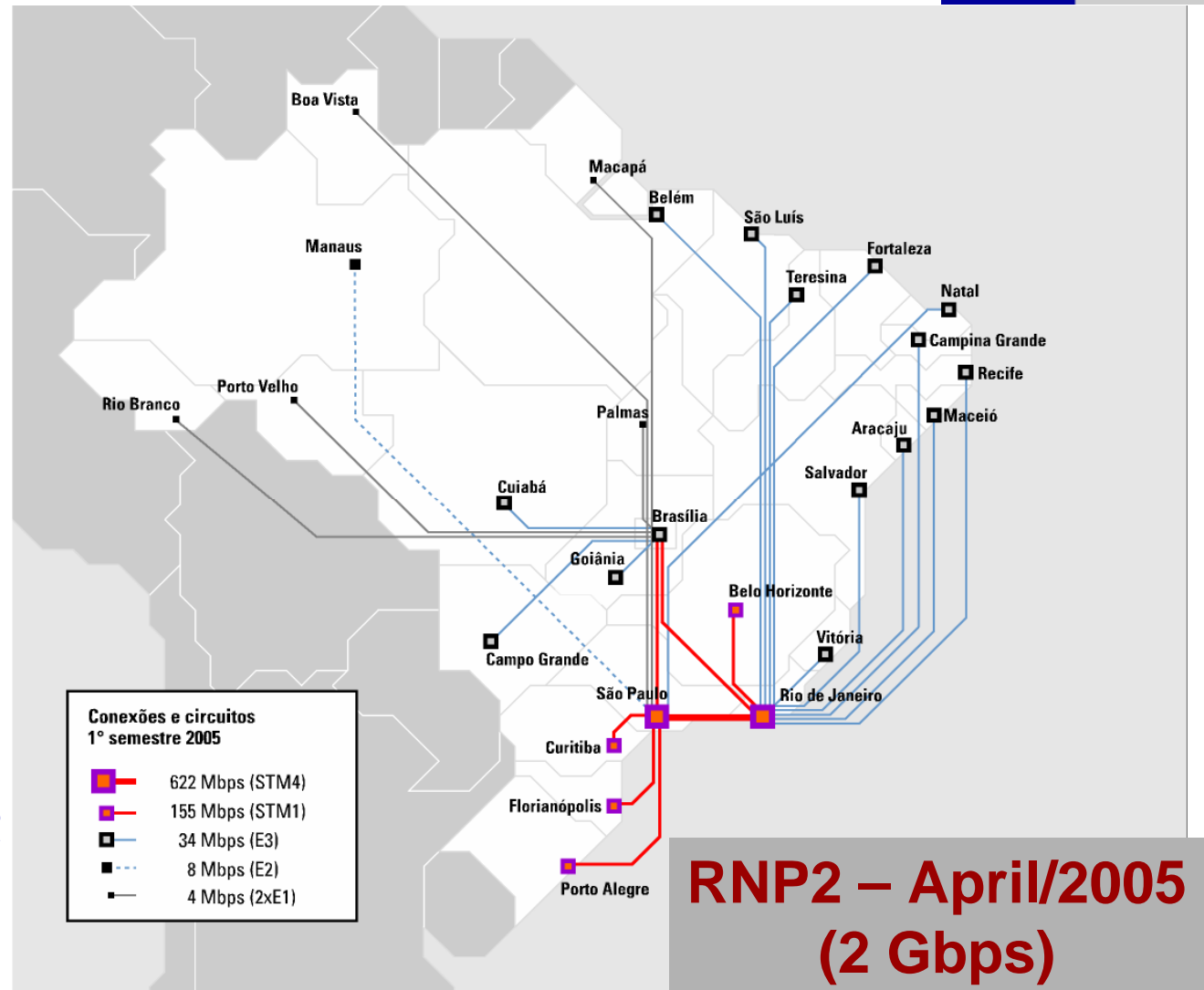

# Project GIGA – optical networking testbed



- Partnership between
  - RNP
  - CPqD (telco industry R&D centre in Campinas, SP)  
[www.cpqd.com.br](http://www.cpqd.com.br)
  - R&D community in industry and universities
- Objectives:
  - Build an advanced networking testbed for development and demonstration purposes
  - Support R&D subprojects in optical and IP networking technology and advanced applications and services
- Industry participation  
(telcos provide the fibres; technology transfer of products and services to Brazilian Industries and telcos required)
- Government funding of US\$ 20 M (via FUNTTEL/Finep) – project started December 2002



# Project Organization

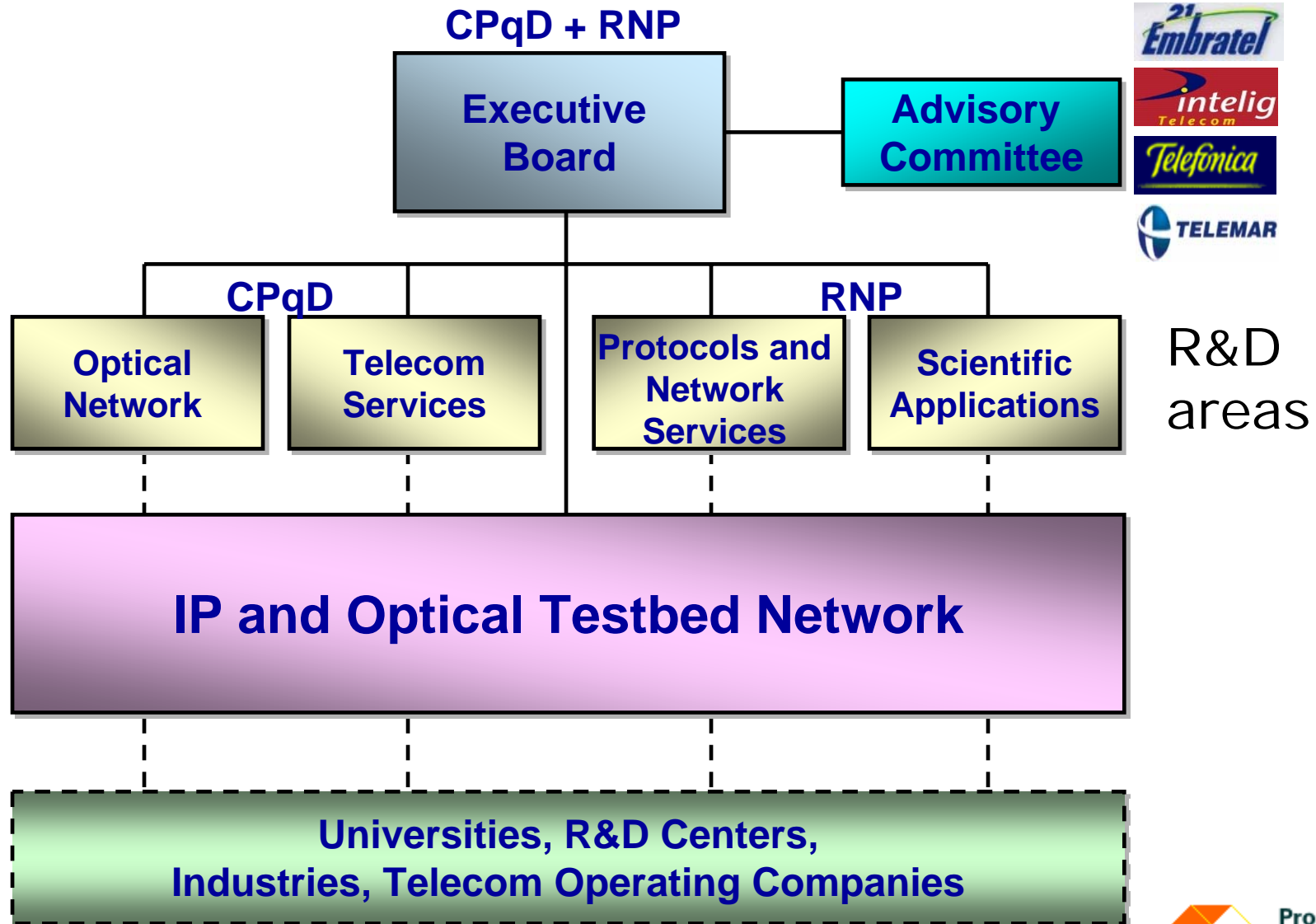

R&D areas

# GIGA testbed network – objectives



- explore user control of optical fibre infrastructure
  - interconnect 20 academic R&D centres in S.E. Brazil
  - use of IP/WDM with Ethernet framing
- provide Networking Research Testbed (NRT) for optical and IP network development
- provide Experimental Infrastructure Network (EIN) for development and demonstration of applications

(NRT and EIN are terms defined by NSF in 2002)

Network was inaugurated in May 2004

# GIGA testbed network – localization



- dark fiber-based 700-km inter-city backbone in states of São Paulo and Rio de Janeiro
- Initially 20 universities and R&D centers in 7 cities
- 2.5G DWDM in the inter-city backbone
- 2.5G CWDM used in the metropolitan area



testbed network

# GIGA testbed network – localization

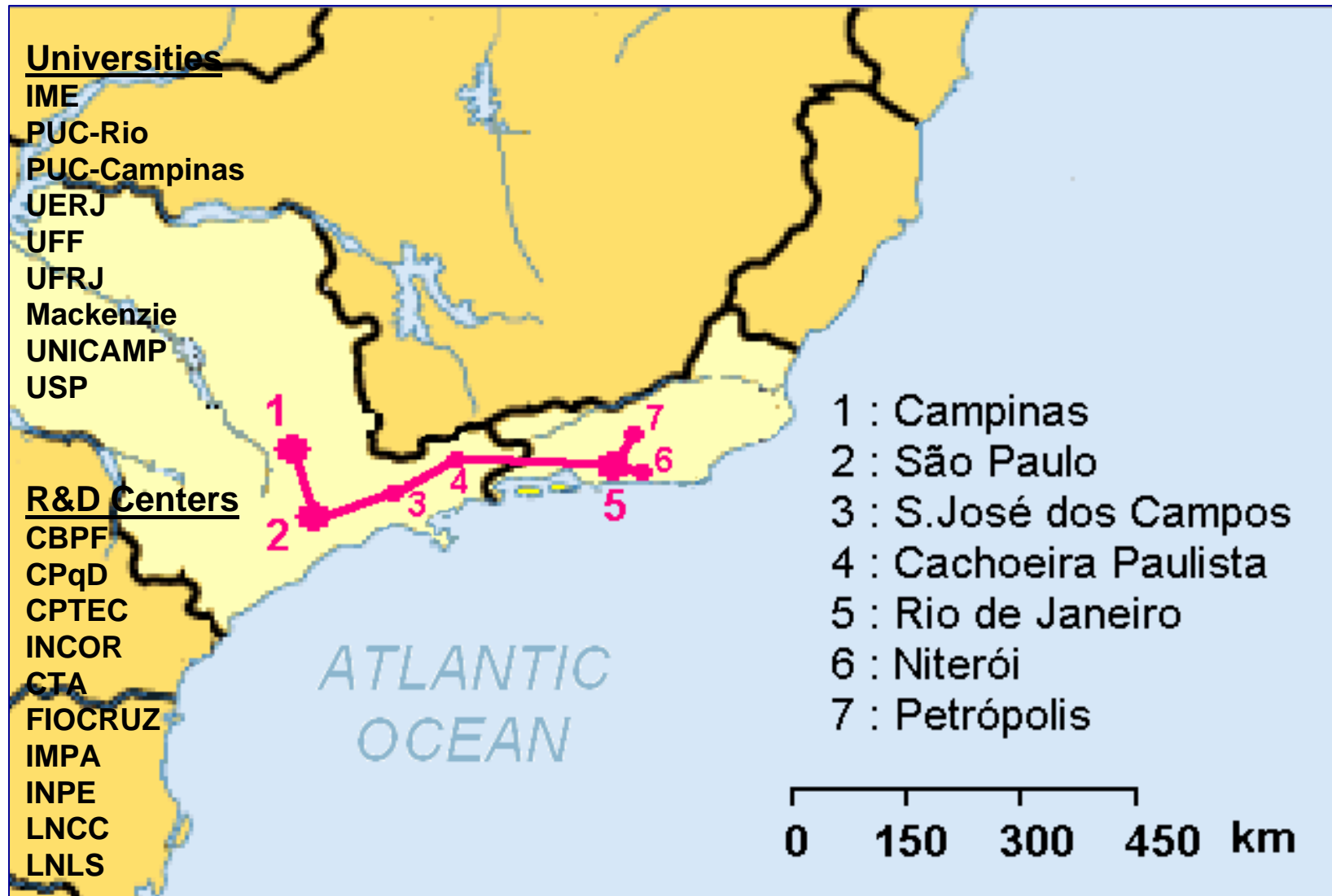

# Initial network design



- 2.5G DWDM inter-city network between Campinas and Rio de Janeiro
  - up to 4 waves per link (can use 8)
- 2.5G CWDM metro networks in São Paulo, Campinas and Rio de Janeiro
- all links currently 1 Gigabit Ethernet
  - optical equipment from Padtec ([www.padtec.com.br](http://www.padtec.com.br))
  - IP equipment from Extreme Networks

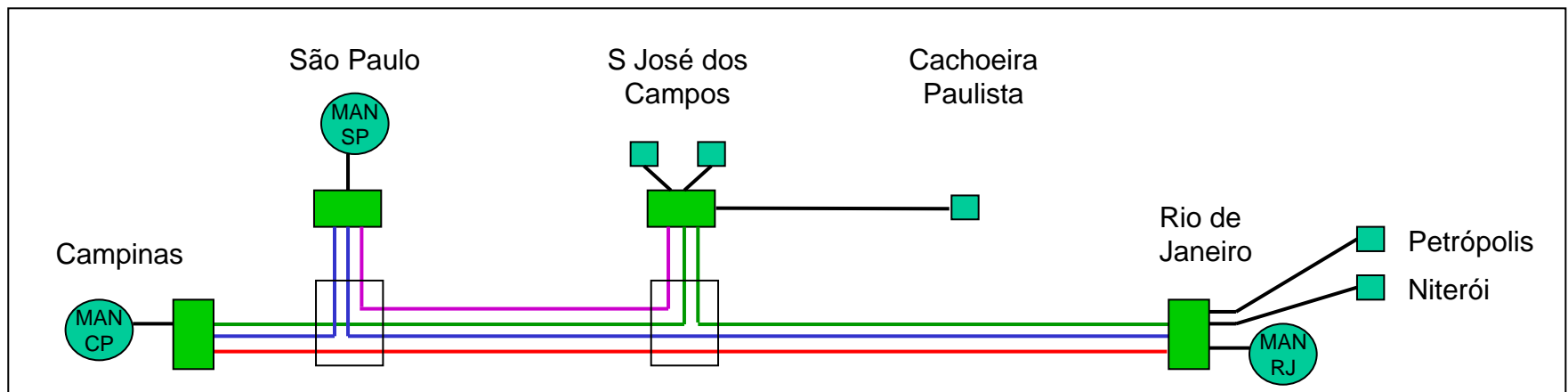
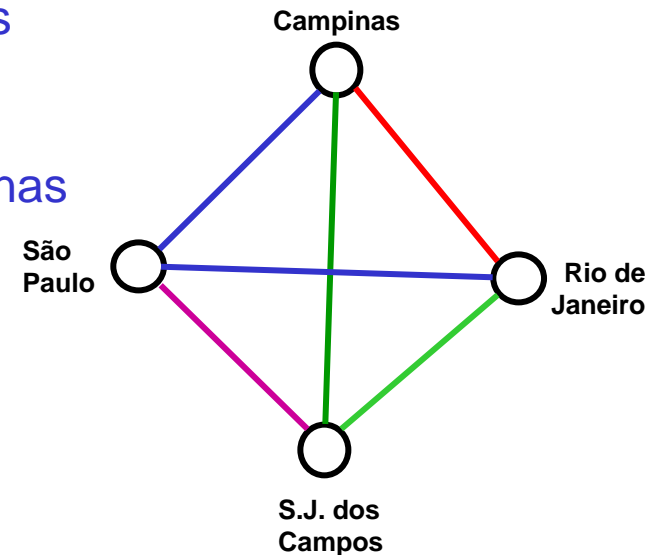

# R&D activities



- 2/3 of the GIGA project budget is for R&D activities in the following areas:
  - Optical networking (CPqD)
  - Network protocols and services (RNP)
  - Experimental telecommunications services (CPqD)
  - Scientific Services and Applications (RNP)
- Most of the R&D activities are contracted out to research groups in the university community (at more than 50 different institutions throughout Brazil)
  - Incentives for technology transfer to industry
  - The network may also be used for the development and/or demonstration of high capacity networking applications by scientific researchers in various areas (HEP, computational biology, earth sciences, environmental sciences, etc), often using grid computing.

# Project Results



- Testbed Network
  - Design and installation
  - In operation since May 2004
- 10G DWDM demonstration
  - 300 km distance without electronic regeneration
  - First step to upgrade the WDM channels to 10G
- Intercontinental HEP GRID Experiments
  - Demonstration at SC2004 (Brazil, USA and Europe) through interconnection with other RNP networks

# International collaboration

- The RedCLARA network (built and maintained through the EuropeAid-financed ALICE project), together with the testbed network, facilitates international communication with other advanced networks
- Evidence of this was given during the Bandwidth Challenge (BWC) during SC2004 in November 2004 in Pittsburgh, USA.
  - participation by HEPGrid group from UERJ (Rio de Janeiro)
  - used GIGA testbed (S. Paulo) RedCLARA (Madrid) GÉANT (NYC) Abilene (about 30.000 km)
  - peak traffic 500 Mbps, sustained traffic 400 Mbps (Nov 10-11)

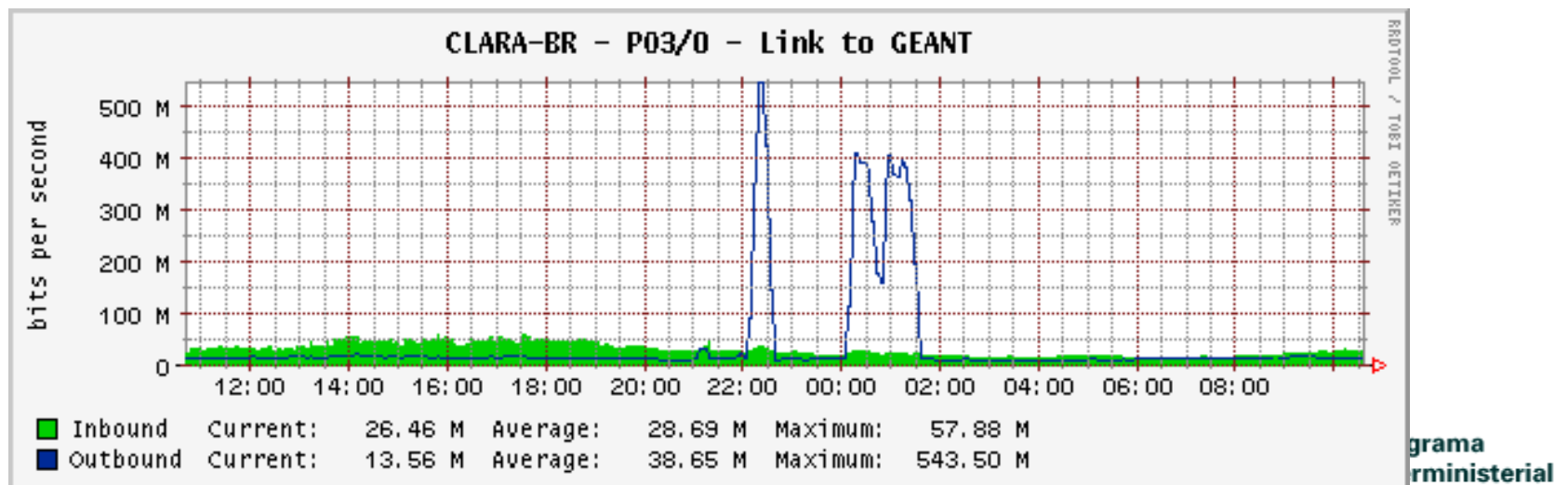

# Optical networks for the R&E community



- Based on practical experience with the testbed network of Project GIGA, RNP is seeking in 2005 to deploy a multi-Gbps network for the national R&E community
- This has two main components:
  - IPÊ multi-Gbps backbone network
    - ipê: (a word in Tupi pronounced “ee-pay”) is Brazil’s national flower (*Tabebuia chrysotricha*)
    - i-pê: IP (Internet Protocol) in Portuguese
    - IPE: Inovação, Pesquisa, Educação (Innovation, Research, Education)
  - Redecomep: community-based optical metropolitan networks
    - for shared local Gbps access to IPÊ PoPs



yellow ipê  
in blossom

# IPÊ: next generation network (2005)



- use of multiple Gbps for interstate links initially between 10 cities
- unprotected 2.5 and 10G waves from two telcos
- only 3x cost of the previous SDH network for around 40x the aggregate capacity
- routers from Juniper Networks (M320, M40)
- to be commissioned in October 2005

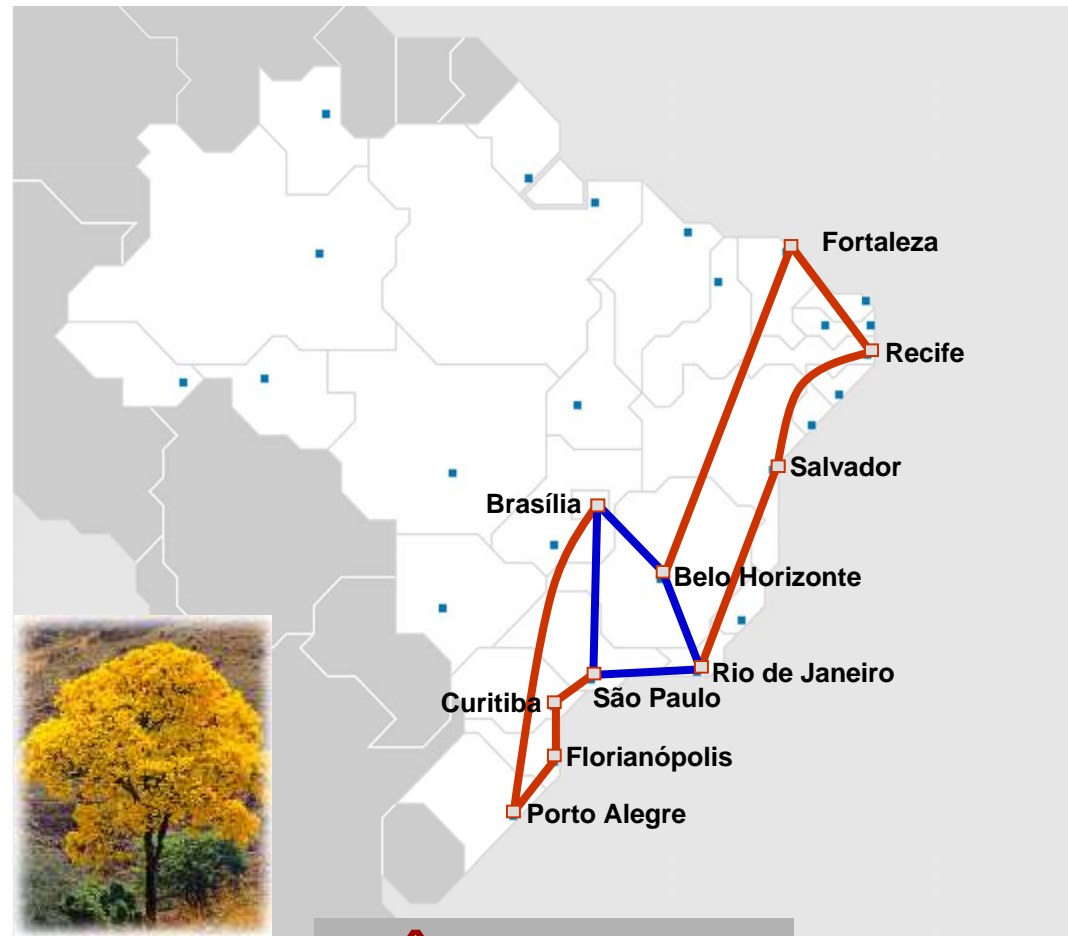

— 2.5 Gbps  
— 10 Gbps

**IPÊ – Oct 2005  
(60 Gbps)**

# Redecomep – Optical Metropolitan Networks for the R&E community



- Long distance networks arrive in a particular point of each city served – Point of Presence (PoP)
- To serve a set of clients in the same city, necessary to provide individual access to the PoP – problem of the Last Mile
- A similar problem arises when we wish to provide connectivity between branches of a single organisation in the same city
- Traditional telco solution to the “problem of the Last Mile”:
  - Rent telco point to point data services to get to PoP
  - Recurrent cost a function of bandwidth
  - Often results in “under-provisioning” due to high cost
- Case study in 2004: Belém, capital of state of Pará (eastern Amazonia) – metropolitan area population of almost 2 millions



# Belém:

## 12 universities and research centers

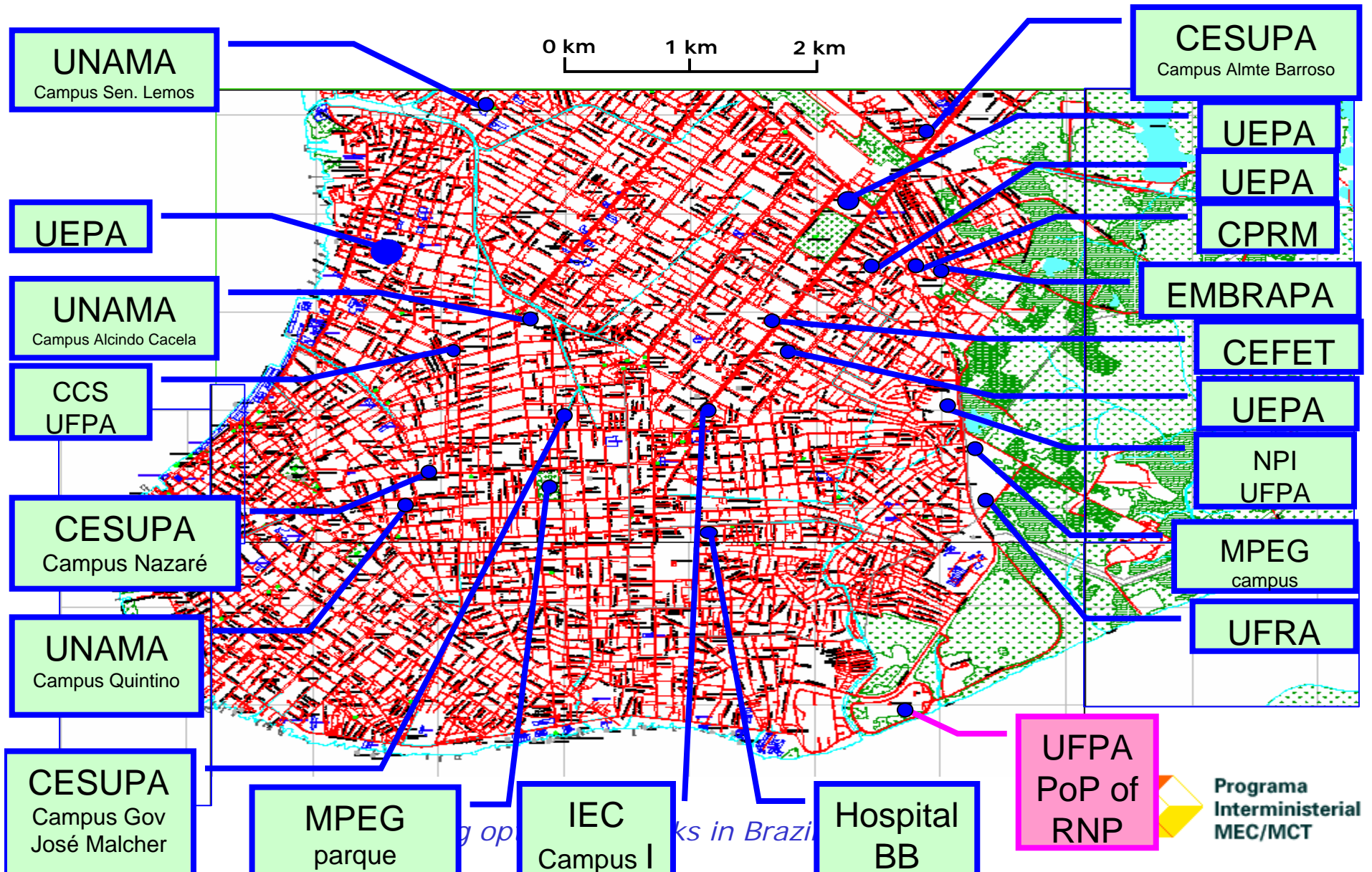

# Situation of local access in Belém in 2004



Institution	Summary of local network connections	Annual cost (US\$)
CEFET	Access to provider at 512 kbps	22,200
CESUPA (4 campi)	Internal + access to provider at 6 Mbps	57,800
IEC/MS (2 campi)	Internal at 512 kbps + access to provider at 512 kbps	13,300
MPEG (2 campi)	Internal at 256 kbps; Access to provider at 34 Mbps (radio link)	7,600
UEPA (5 campi)	Internal at 128 kbps; access to provider at 512 kbps	18,500
UFPA (4 campi)	Internal at 128 kbps; Provider PoP	16,700
UFRA	Access to provider at 1 Mbps	16,000
UNAMA (4 campi)	Internal wireless links, access to provider at 6 Mbps	88,900

Total telco charges for POOR local access = US\$ 241,000 p.a.

# An alternative approach – DIY (do-it-yourself) community networking



1. Form a consortium for joint network provision
  2. Build your own optical fiber network to reach ALL the campi of ALL consortium members
  3. Light it up and go!
- Costs involved:
    - Building out the fiber: using utility poles of electric company
      - US\$ 8,000 per km
      - Monthly rental of US\$1 (about 40 poles per km)
    - Equipment costs: mostly use cheap 2 port GigE switches
    - Operation and maintenance
  - In Belém for 12 institutions using all GigE connections:
    - Capital costs around US\$500,000
    - Running costs around US\$80,000 p.a.
    - Compare with current US\$240,000 p.a. for traditional telco solution

# Some architectural details



- Use dedicated fiber pair for each separate institution to permit:
  - Building an internal corporate network
  - Providing access to the PoP
- A physical ring topology is desirable to provide protection through redundancy

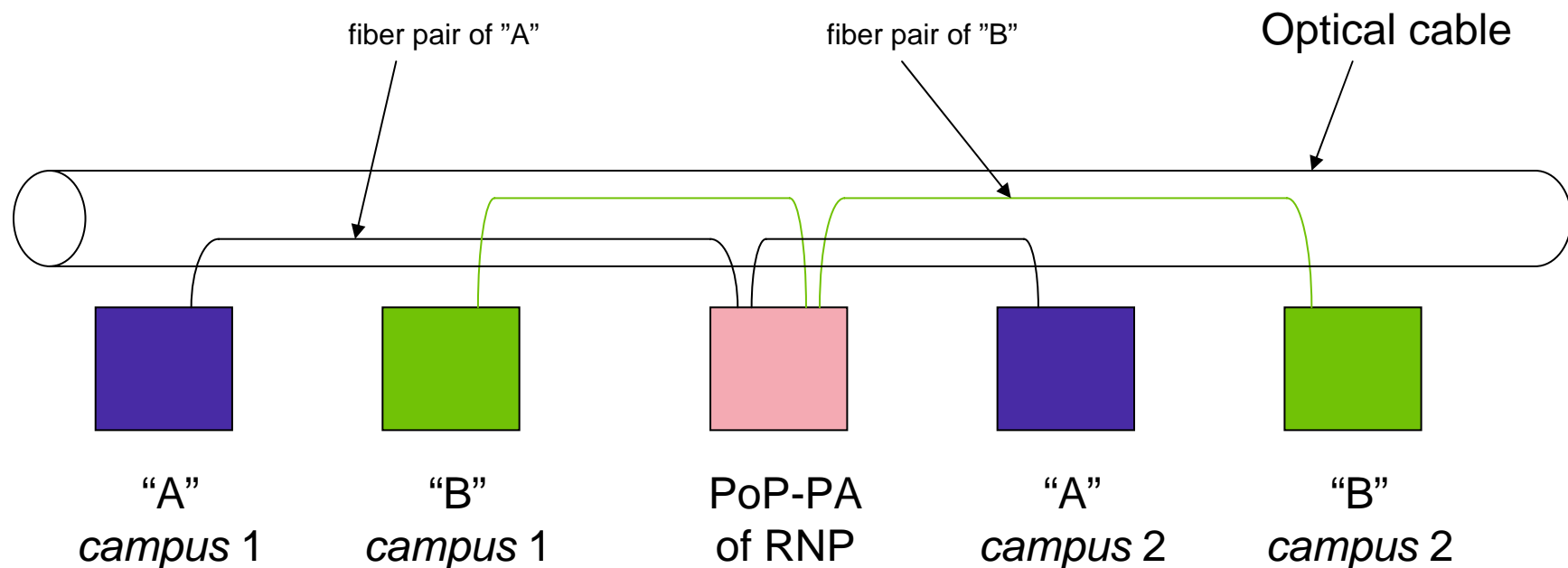

# Architecture 1: star of rings

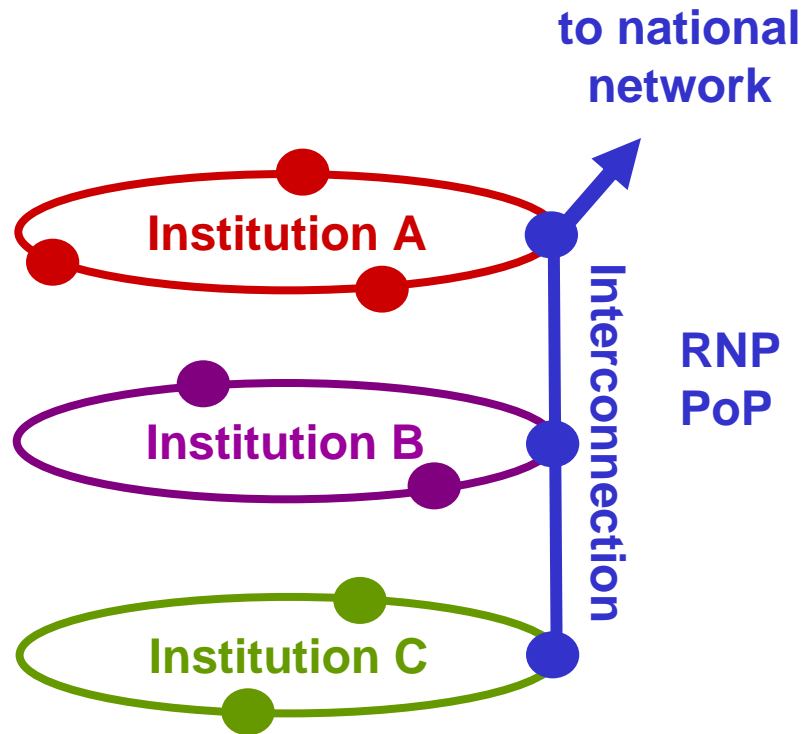

- uses a dedicated fiber pair for each client institution for corporate network
- all fibers meet at the RNP PoP – interconnection point
- needs a large routing switch at PoP
- other switches are simpler, with two optical ports

# Architecture 2: ring of rings

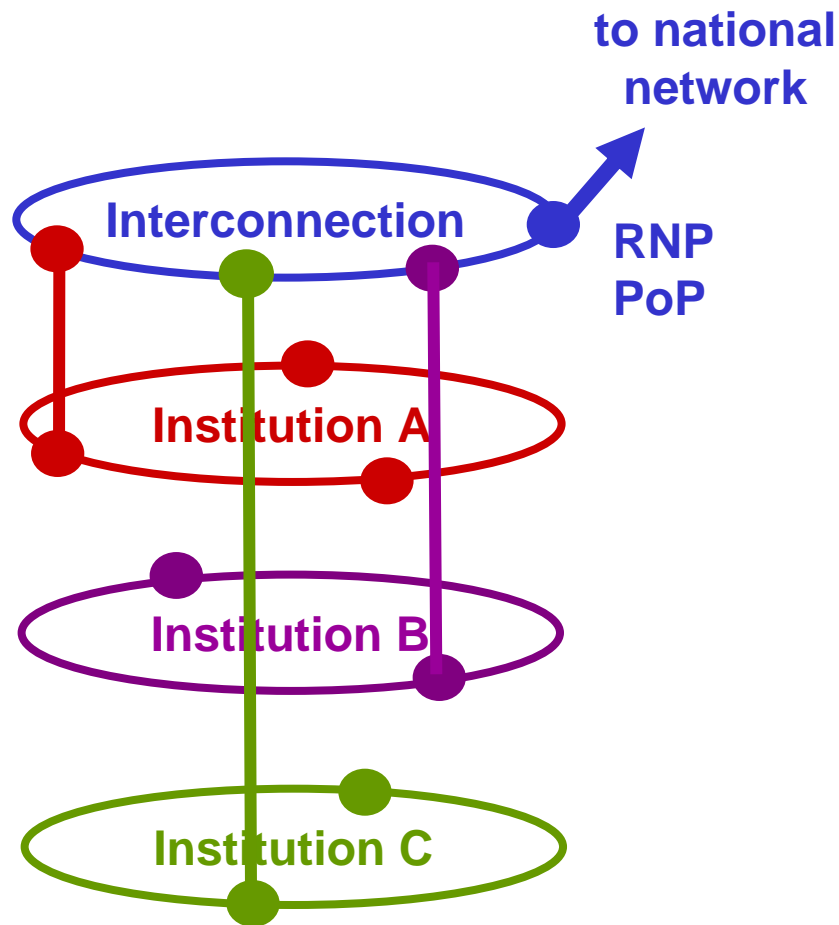

- uses a dedicated fiber pair for each client institution for corporate network
- an additional fiber pair provides interconnection between one (or more) points of each corporate network
  - simpler switch suffices at RNP PoP
  - interconnection points require at least 4 optical interfaces

# Belém: a possible topology (30 km ring)

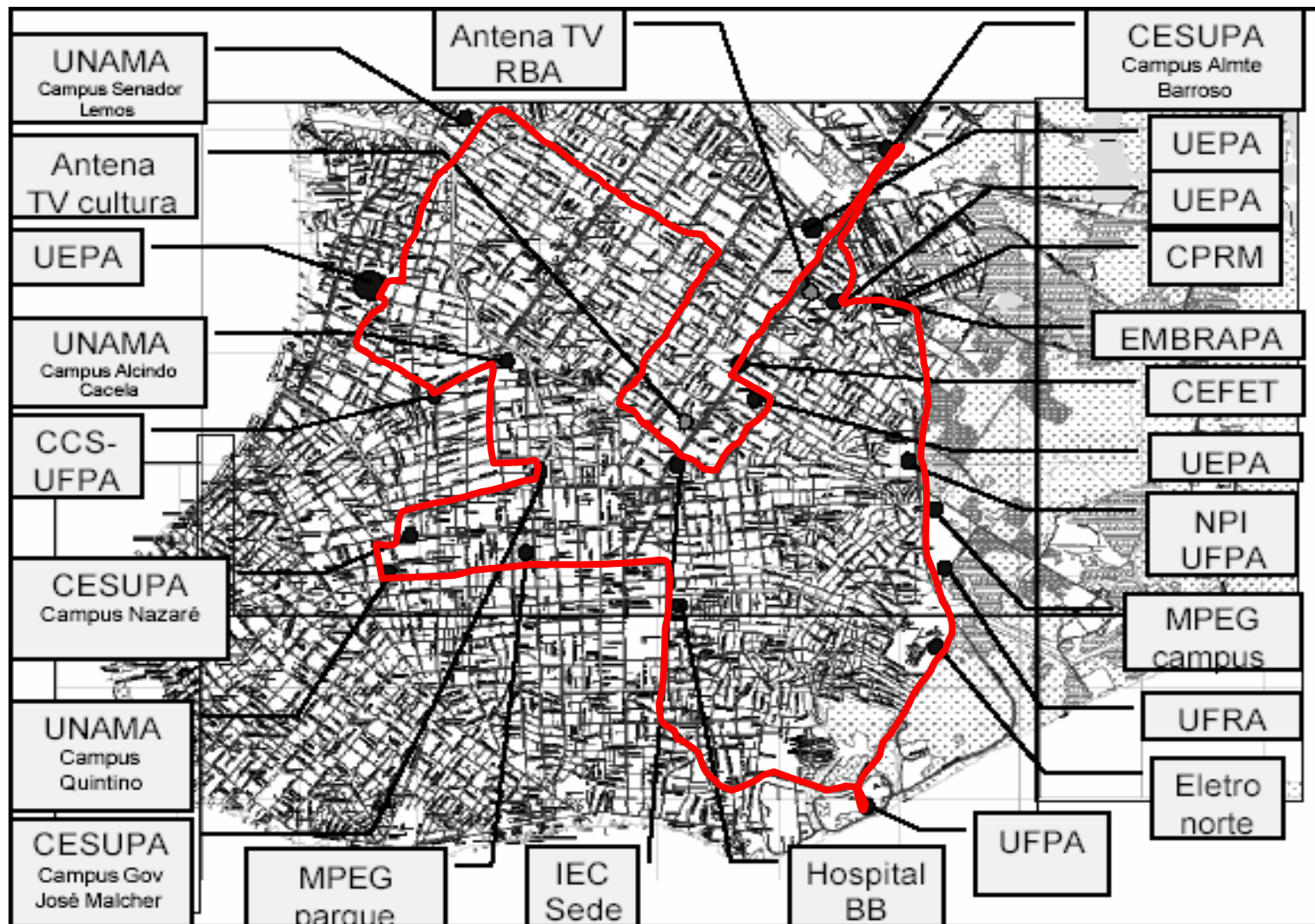

# RNP activities in metro networks 2005/6



- In December 2004, RNP obtained financing from Finep (agency of the ministry of Science and Technology) to build optical metro networks in all 27 capital cities in Brazil (projects MetroBel and Redecomep)
- Total value of more than US\$15 millions to be spent by December, 2006
- Tender for cabling Belém published in August
- Joint equipment tender published in September
- Currently plans are under way for installing metro networks in the following cities:  
Manaus, Belém, Fortaleza, Natal, Recife, Salvador, Vitória, Brasília, Curitiba, Florianópolis, Porto Alegre



*Building optical networks in Brazil*

# ION – National Optical Initiative



- Since 2002 RNP has been actively searching for strategic partners, with assets in dark fiber or WDM, that are interested in collaborating in the creation of high-capacity networks for the research and education community
- the most likely partners are oil or electrical energy companies owned by the federal government (Petrobrás, Eletrobrás)
  - the oil company has installed optical fiber along oil/gas pipelines
  - the electrical companies have installed OPGW along their high-voltage transmission lines
- First serious opportunity in 2004 with CHESF, the subsidiary of Eletrobrás serving NE Brazil, which is studying sharing its optical fiber infrastructure with RNP
  - project is called ION-NE – ION in the NE

# ION-NE = testbed + IPÊ



- Fiber was lent to Project GIGA for 5 years and these contracts are renewable.
  - Both the Brazilian government and the R&D community wish to extend the research testbed to other parts of Brazil.
  - An opportunity is being pursued in NE Brazil, to install there an extension of the testbed network, using fiber of the state-owned electrical company, CHESF.
  - Strong synergy with development of the IPÊ network – the next phase of development of RNP's service network to support Research and Education (R&E)
- ➔ Project ION-NE: WDM transport network in NE Brazil to provide
- ➔ Production IP service for R&E institutions
  - ➔ Extension of the testbed network to R&D institutions in the NE

# Project ION-NE: WDM transmission network

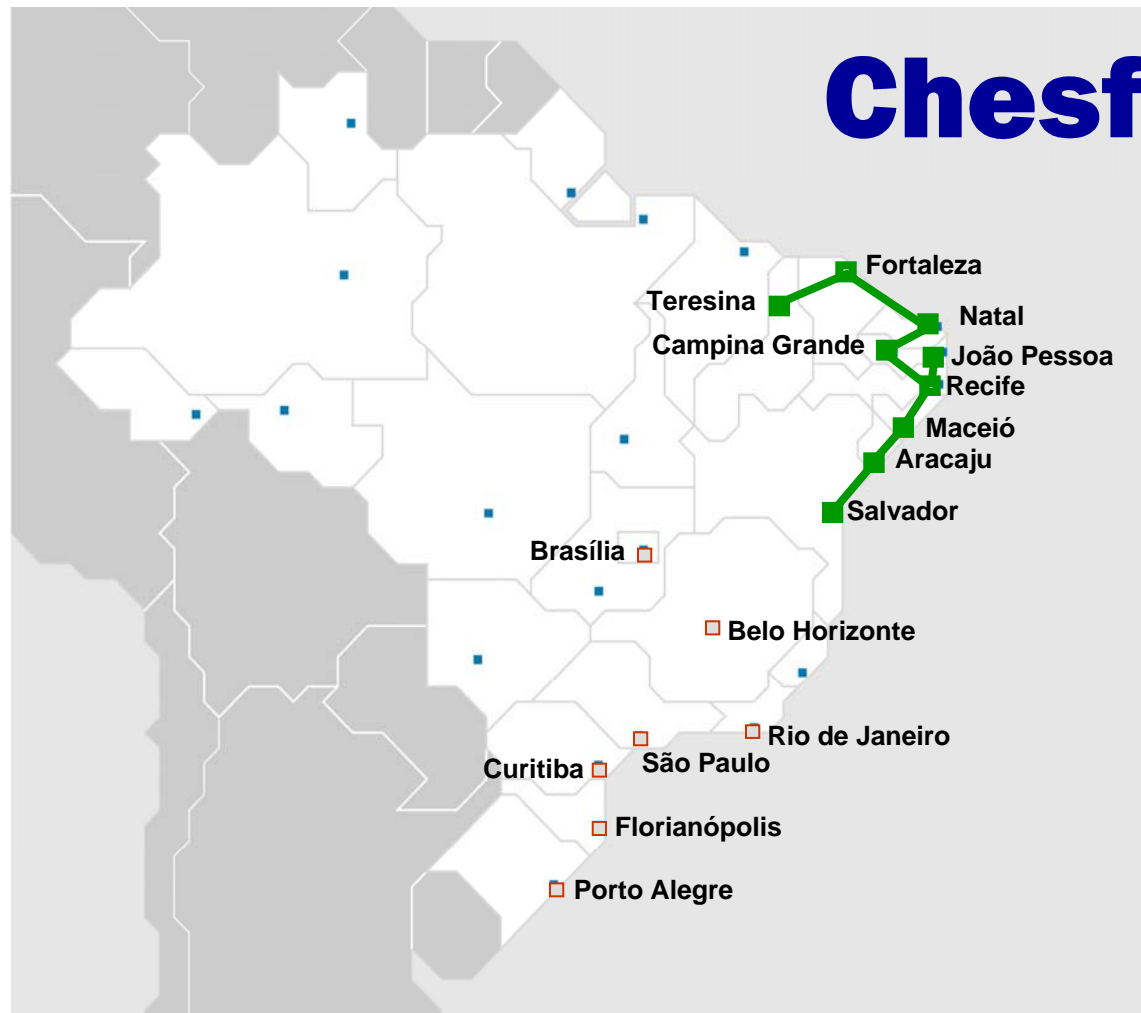

*Building optical networks in Brazil*

# Project ION-NE: integration with IPÊ



IPÊ backbone  
(2.5 and 10G)  
in 2005

# Project ION-NE: extension of Project GIGA testbed

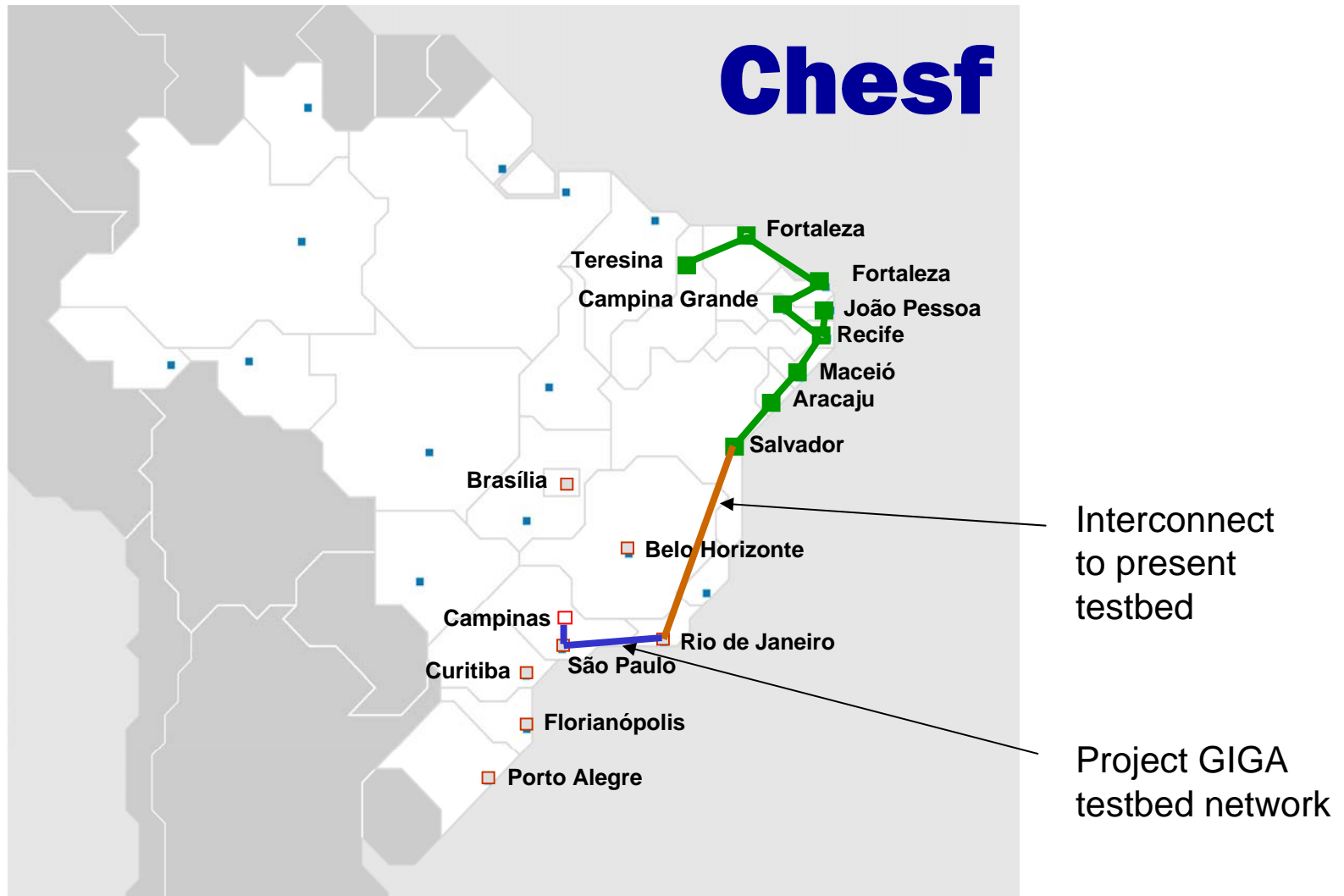

# Project ION-NE: future of Project GIGA



Project GIGA expected to last until the end of 2006.

- We have as a product a large laboratory for R&D in telecommunications and advanced networking – the testbed
- Project ION-NE should extend this testbed from 700 to 4.000 km, connecting R&D institutions in cities in NE Brazil.

Project ION-NE also expected to include support, from 2007, for:

- maintenance and operation of the extended testbed network
- new R&D activities in telecom and advanced networking using the extended testbed

# Future perspectives



- The model of working in partnership with the federal electrical companies has several advantages:
  - the 4 major companies have national coverage with (mainly) OPGW cabling
  - the model being used is a partnership, sharing the same fiber and WDM transmission system with the electrical company
    - The company has a serious interest in maintaining and operating the transmission system
  - Optical transmission equipment costs:
    - Installing 2,5 Gbps DWDM on CHESF fibres costs around US\$2,000 per km (lots of OADMs to handle CHESF capillarity)
    - Costs can be as low as US\$1,100 per km for long runs without branching

# The cost of a national WDM network



- Consider the present Eletronet footprint (based on federal electrical companies' transmission lines)
  - 16,000 km extension – touches 18 of Brazil's 27 states
- Using CHESF costs, we have CapEx not more than US\$ 32 M
  - Compare with RNP's current annual telco costs of US\$13 M
- Optical metro networks currently under construction will provide local access in the cities reached

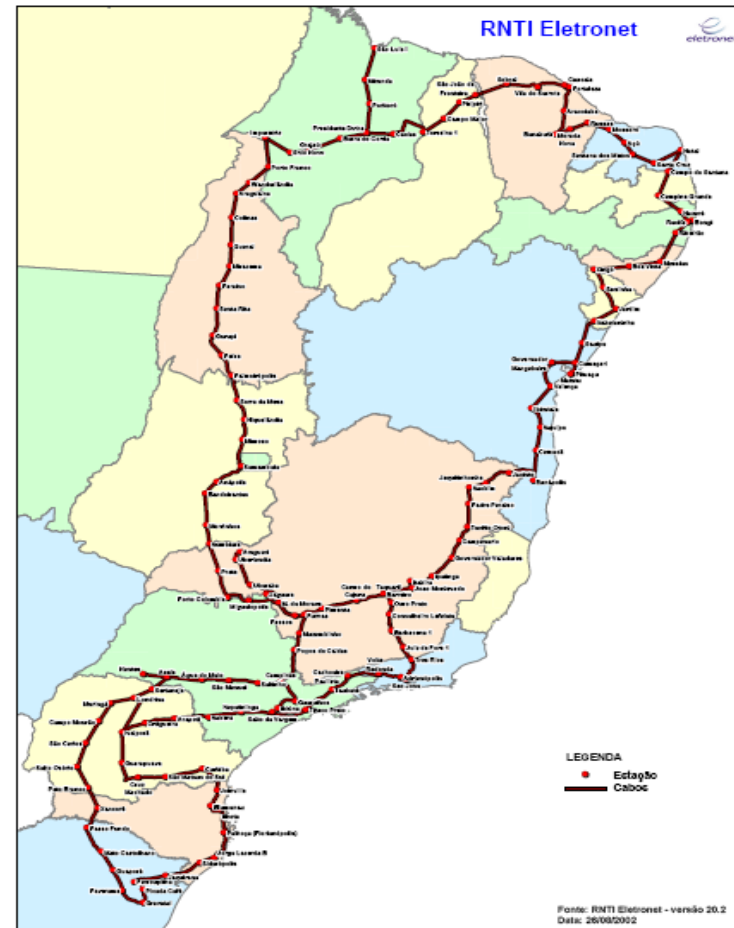



***Thank you!***

Michael Stanton  
([michael@rnp.br](mailto:michael@rnp.br))

[www.rnp.br](http://www.rnp.br)